

NOTES FOR STANDARD CONSTRUCTION:
 ...MEETS FMCSA REQUIREMENTS.
 ...PRESSURE TESTED @ 5psi
 ...INTERIOR FREE OF FOREIGN MATTER.
 ...FILLER CAP, DRAIN PLUG & VENT PROVIDED.
 ...FULL BAFFLE(S) WHERE SHOWN
 ...ALUMINUM CONSTRUCTION:
 5052-H32 ALUMINUM, BRIGHT FINISH
 HEADS ARE 0.100" & SHELL IS 0.125"
 ...ALL OPENINGS PLUGGED PRIOR TO SHIPPING

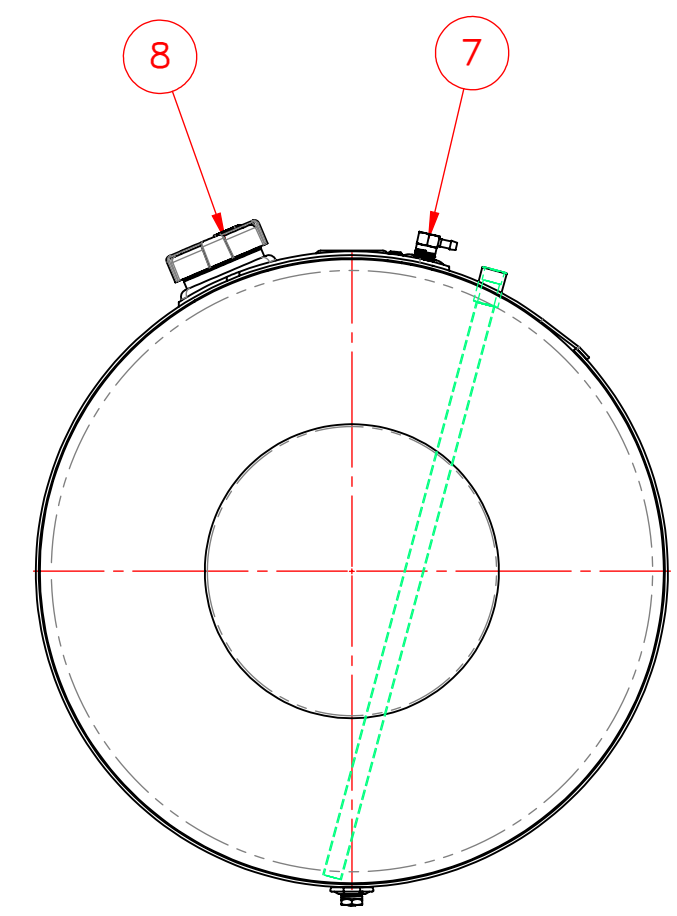
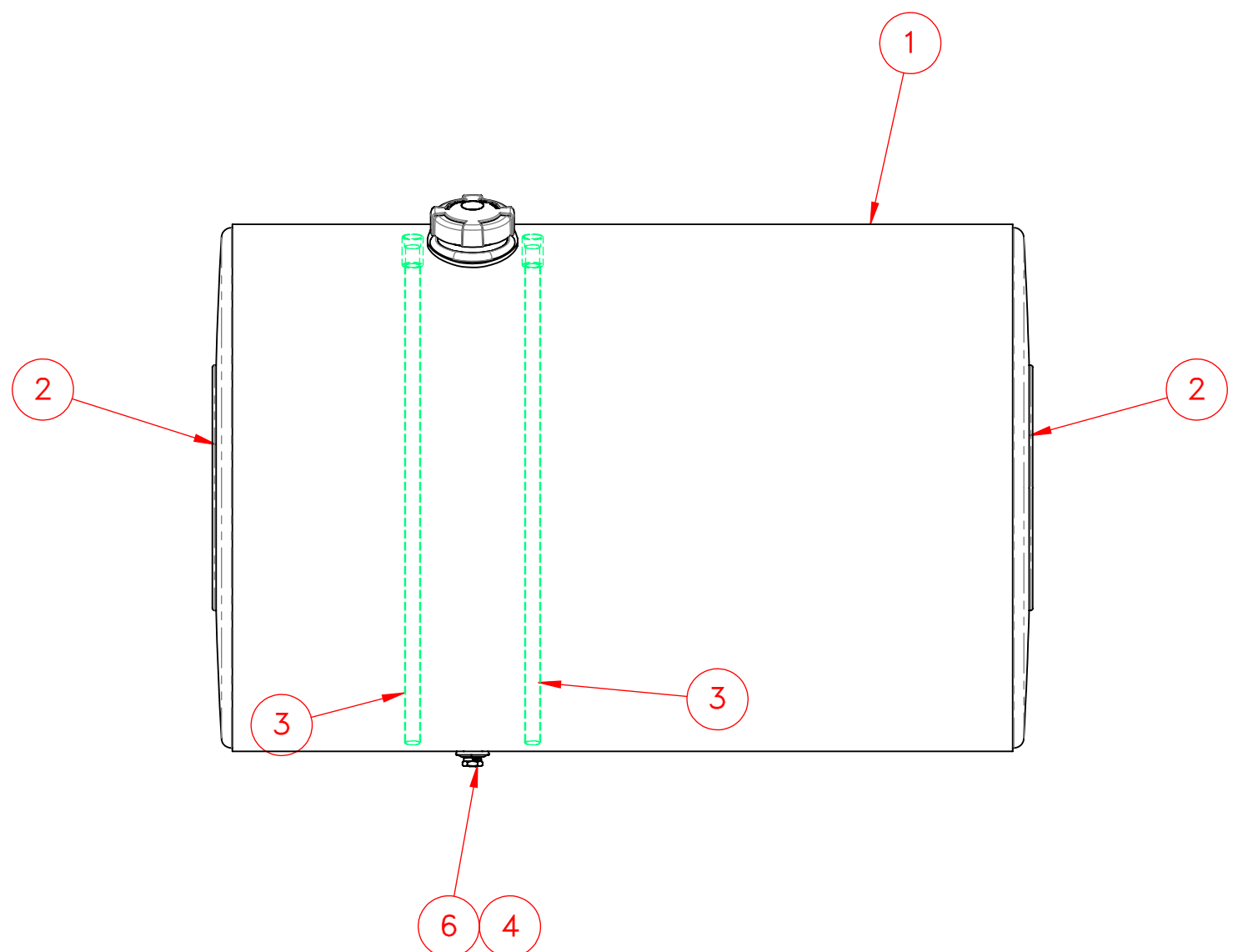
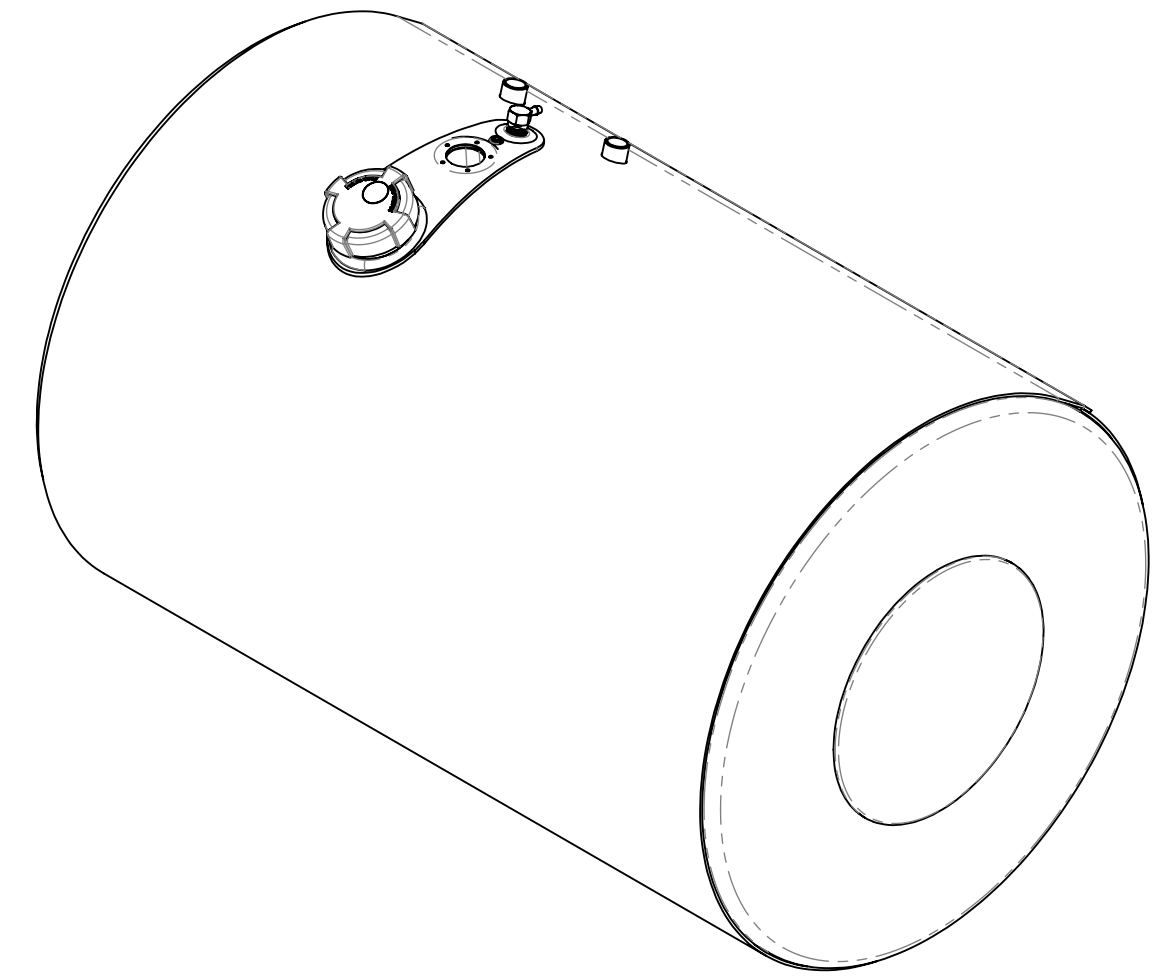

ITEM NO.	PART NUMBER	DESCRIPTION	QTY.
1	116-0312	1/8" Auminum Wrap	1
2	160-0056	26" Aluminum Head	2
3	490-0101	1/2" FNPT Down Tube	2
4	260-0005	1/2" FNPT Aluminum weld flange	1
5	260-0734	Aluminum 3" Filler/Float/Vent Plate	1
6	458-0100	1/2" NPT Ball Check Drain Plug	1
7	454-0937	1/2" NPT Ball Check Vent	1
8	452-1628	Fuel Cap 3" Pressure Relief	1
9	368-0005	1/4" NPT Brass Drain Plug Hex	1

PROPOWER MFG. INC.
 WINDSOR, ONTARIO, CANADA
 Ph: 519-737-1197 Fax: 519-737-1918
 TOLL FREE 1-877-741-2365 Web: metaltanks.com

UNLESS OTHERWISE SPECIFIED:
 DIMENSIONS ARE IN INCHES
 TOLERANCES:
 FRACTIONAL ± 1/16
 ANGULAR: MACH ± 1° BEND ± 1°
 TWO PLACE DECIMAL ± .06
 THREE PLACE DECIMAL ± .031

PROPRIETARY AND CONFIDENTIAL
 THE INFORMATION CONTAINED IN THIS DRAWING IS THE SOLE PROPERTY OF PROPOWER MFG. INC. ANY REPRODUCTION IN PART OR AS A WHOLE WITHOUT THE WRITTEN PERMISSION OF PROPOWER MFG. INC. IS PROHIBITED.

DRAWN	NAME	DATE
CHECKED	A.B	04/03/13
ENG APPR.		
MFG APPR.		
Q.A.		
COMMENTS:		

MATERIAL: **ALUMINUM**

FINISH: _____

DO NOT SCALE DRAWING

THIRD ANGLE PROJECTION

TITLE:
MK-L26CFA41
 94 US GROSS GALLONS
 89 USEBLE GALLONS
 DIESEL FUEL TANK

SIZE DWG. NO. REV
C 15064

SCALE: 1:8 WEIGHT: 55 LBS SHEET 1 OF 2