

DETAIL A  
SCALE 1 : 2

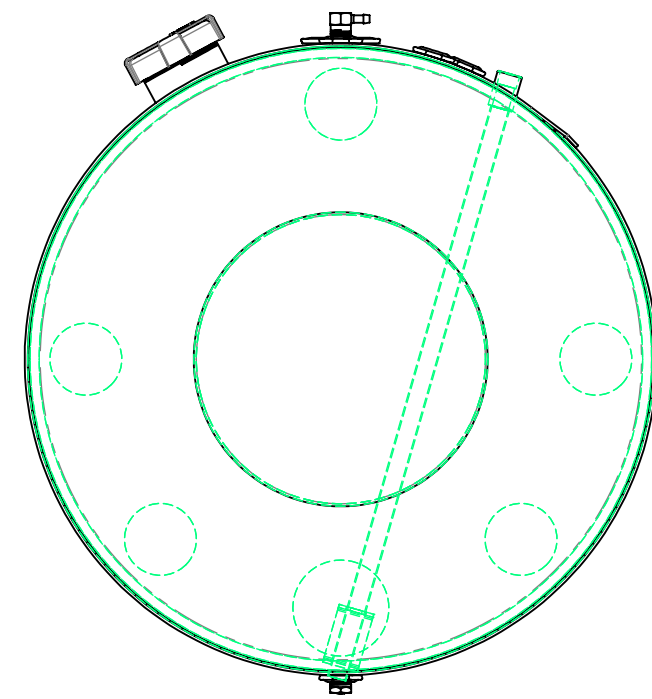
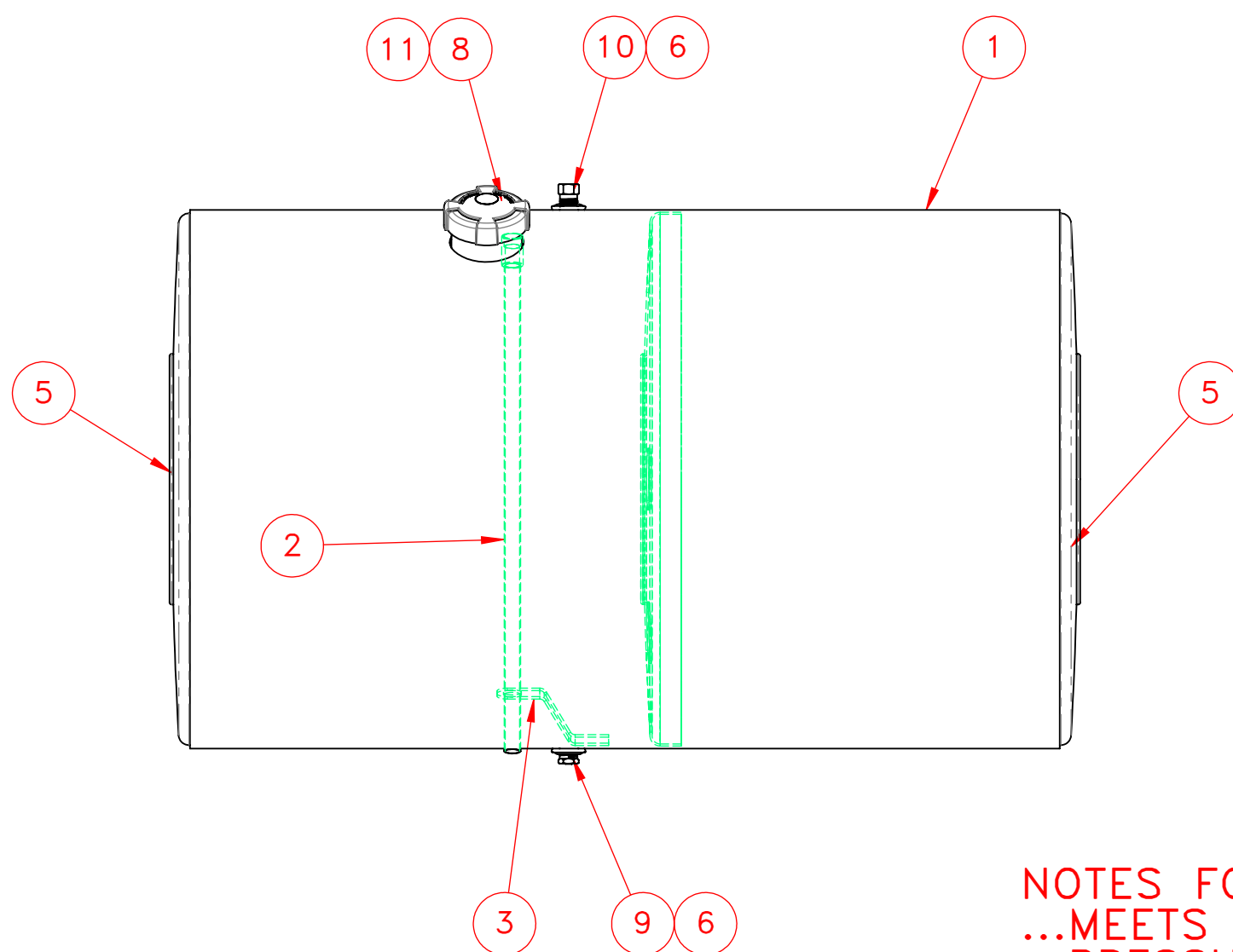
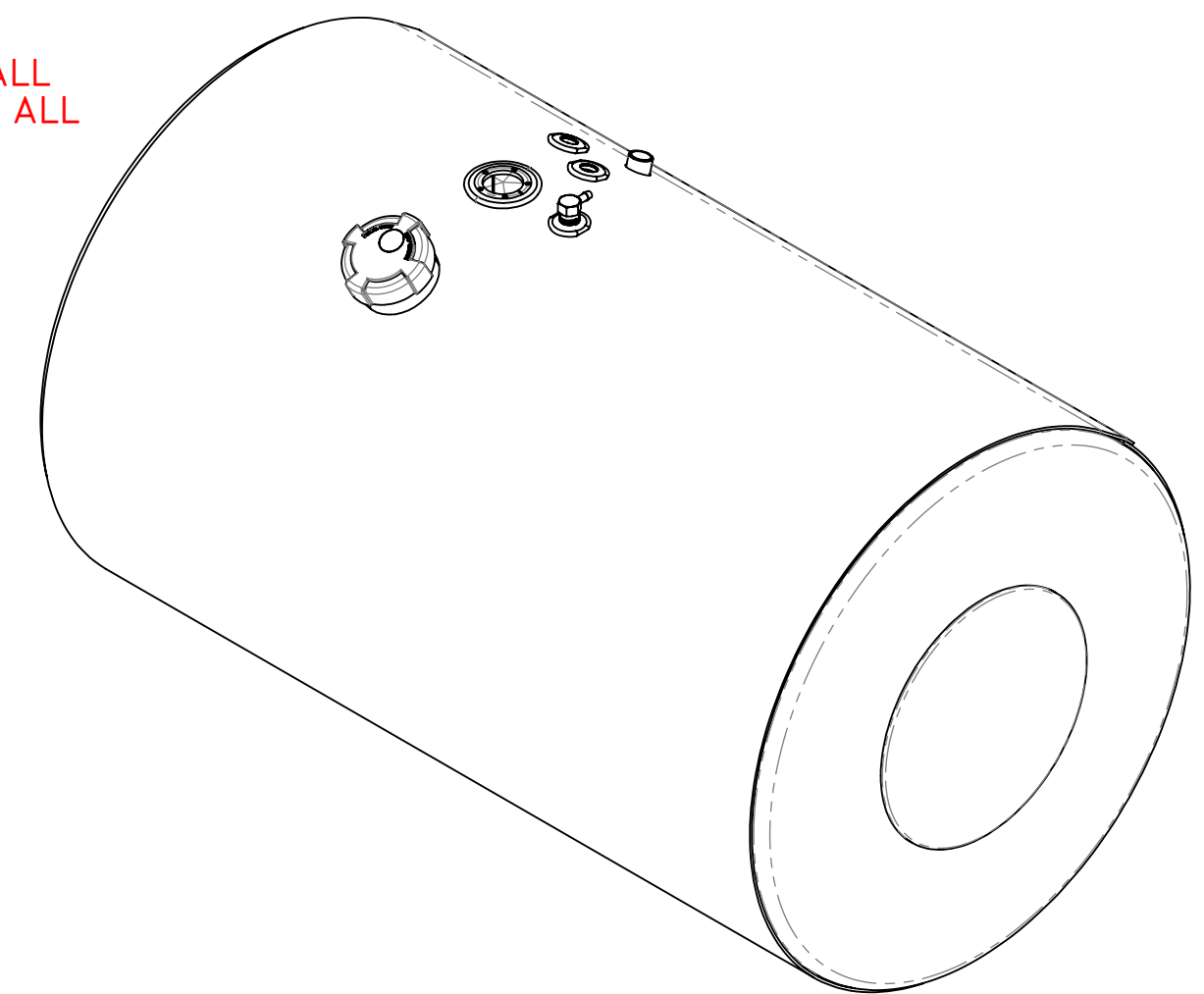

NOTES FOR STANDARD CONSTRUCTION:  
 ...MEETS FMCSA REQUIREMENTS.  
 ...PRESSURE TESTED @ 5psi  
 ...INTERIOR FREE OF FOREIGN MATTER.  
 ...FILLER CAP, DRAIN PLUG & VENT PROVIDED.  
 ...FULL BAFFLE(S) WHERE SHOWN  
 ...ALUMINUM CONSTRUCTION:  
 5052-H32 ALUMINUM, BRIGHT FINISH  
 HEADS ARE 0.100" & SHELL IS 0.125"  
 ...ALL OPENINGS PLUGGED PRIOR TO SHIPPING

ITEM NO.	PART NUMBER	DESCRIPTION	QTY.
1	116-0507	1/8" Auminum Wrap	1
2	490-0101	1/2" FNPT Down Tube	1
3	490-3001	Down Tube Support	1
4	162-0056	26" Aluminum Baffle	1
5	160-0056	26" Aluminum Head	2
6	260-0005	1/2" FNPT Aluminum weld flange	4
7	265-0009	Aluminum Float Riser	1
8	316-0014	3" Aluminum Filler Neck	1
9	458-0100	1/2" NPT Ball Check Drain Plug	1
10	454-0937	1/2" NPT Ball Check Vent	1
11	452-1628	Fuel Cap 3" Pressure Relief	1

UNLESS OTHERWISE SPECIFIED: DIMENSIONS ARE IN INCHES TOLERANCES: FRACTIONAL ± 1/16 ANGULAR: MACH ± 1° BEND ± 1° TWO PLACE DECIMAL ± .06 THREE PLACE DECIMAL ± .031	DRAWN	NAME	DATE	PROPOWER MFG. INC. WINDSOR, ONTARIO, CANADA Ph: 519-737-1197 Fax: 519-737-1918 TOLL FREE 1-877-741-2365 Web: metaltanks.com
	CHECKED	A.B	07/09/14	
	ENG APPR.			
	MFG APPR.			
INTERPRET GEOMETRIC TOLERANCING PER:	COMMENTS:			TITLE:
MATERIAL	ALUMINUM			WS-L26CFA44.5
FINISH				102 US GROSS GALLONS
DO NOT SCALE DRAWING	THIRD ANGLE PROJECTION			97 USEBLE GALLONS
		SCALE: 1:8	WEIGHT: 64 LBS	SHEET 1 OF 2